

TB 1-1520-248-30-05

CHANGE
NO. 2

HEADQUARTERS
DEPARTMENT OF THE ARMY
WASHINGTON, D.C., 30 NOVEMBER 2005

TECHNICAL BULLETIN

**INTERMEDIATE WEIGHT REDUCTION IMPLEMENTATION
ON OH-58D HELICOPTERS**

(NSN 1520-01-125-5476)

DISTRIBUTION STATEMENT A: Approved for public release; distribution is unlimited.

TB 1-1520-248-30-05, 25 September 2003 is changed as follows:

1. Remove and insert pages as indicated below. New or changed text material is indicated by a vertical bar in the margin. An illustration change is indicated by a miniature pointing hand.

Remove pages

1 and 2
19 through 24
25/26 Blank

Insert pages

1 and 2
19 through 24
25 and 26

2. Retain this sheet in front of manual for reference purposes.

By Order of the Secretary of the Army:

Official:

SANDRA R. RILEY
*Administrative Assistant to the
Secretary of the Army*
0531303

PETER J. SCHOOMAKER
*General, United States Army
Chief of Staff*

DISTRIBUTION:

To be distributed in accordance with the Initial Distribution Number (IDN) 314100, requirements for TB 1-1520-248-30-05.

CHANGE
NO. 1

TB 1-1520-248-30-05
U.S. ARMY AVIATION AND MISSILE COMMAND
REDSTONE ARSENAL, AL 35898-5000
31 MAY 2005

TECHNICAL BULLETIN

**INTERMEDIATE WEIGHT REDUCTION IMPLEMENTATION
ON OH-58D HELICOPTERS
(NSN 1520-01-125-5476)**

DISTRIBUTION STATEMENT A: Approved for public release; distribution is unlimited.

TB 1-1520-248-30-05 25, SEPTEMBER 2003, is changed as follows:

1. Remove and insert pages as indicated below. New or changed text material is indicated by a vertical bar in the margin. An illustration change is indicated by a miniature pointing hand.

Remove pages

24 and 25

Insert pages

24 and 25

2. Retain this sheet in front of manual for reference purposes.

By Order of the Secretary of the Army:

Official:



SANDRA R. RILEY
*Administrative Assistant to the
Secretary of the Army*
0509407

PETER J. SCHOOMAKER
*General, United States Army
Chief of Staff*

URGENT

*TB 1-1520-248-30-05

DEPARTMENT OF THE ARMY TECHNICAL BULLETIN

INTERMEDIATE WEIGHT REDUCTION IMPLEMENTATION ON OH-58D HELICOPTERS

Headquarters, Department of the Army, Washington, D.C.
25 September 2003

DISTRIBUTION STATEMENT A: Approved for public release; distribution is unlimited.

NOTE

This publication is effective until rescinded or superseded.

1. **PURPOSE.** To improve the operational weight conditions and the power available margin of the OH-58D helicopter by removing non-mission essential and/or obsolete components.

2. **PRIORITY.** This technical bulletin is classified **URGENT**.

3. **APPLICABLE END ITEM(S) OR SYSTEM(S).**

NOMENCLATURE	NSN	CAGE	MODEL	SERIAL #
Helicopter, Observation	1520-01-125-5476	97499	OH-58D	ALL

4. **APPLICATION.** N/A

5. **TASK/INSPECTION SUSPENSE DATE.**

a. Inspection Suspense Date: N/A

b. Repair: Repairs to discovered maintenance defects shall be accomplished prior to next flight.

6. **REPORTING COMPLIANCE SUSPENSE DATE.** N/A

*This TB supersedes TB 1-1520-248-30-05, 18 July 2003.

URGENT

7. SUMMARY OF PROBLEM.

- a. The implementation for this TB Weight Reduction Effort is to accomplish the following:
 - (1) Removal of the AN/ARC-199 HF Mount and Antenna (406-077-109-101).
 - (2) Removal of the installation provisions for the Communication Security Set (TSEC/KY-75) (5810-01-050-2502).
 - (3) Removal of the installation provisions for the ATAS Pilot Display Unit (PDU) (i.e. mount, Sight, and electronic cables).
 - (4) Removal of the operational provisions for the Cargo Hook (i.e. cargo release handle and cables).
 - (5) Removal of the FM Homing Comparator and Coupler.
 - (6) Removal of the left FM Antenna.
 - (7) Removal of the Armor Plates on the Engine Cowling.
- b. For Manpower/Downtime and funding impacts see Para 11.
- c. The purpose of the Technical Bulletin is to provide a method to remove hardware/components which are no longer required on the aircraft and provide a reduction in weight.

8. END ITEMS TO BE INSPECTED/REPAIRED. All OH-58D and OH-58D(R) aircraft.

9. ASSEMBLY COMPONENTS TO BE INSPECTED. N/A

10. PARTS TO BE INSPECTED. N/A

11. PROCEDURES.

WARNING

Ensure helicopter condition is safed in accordance with (IAW) TM 1-1520-248-23 (Task 1-6-7).

WARNING

To prevent compromising helicopter flight characteristics and consequent possible injury to personnel, Weight and Balance Records shall be updated to show true helicopter configuration when changes are made. The aircraft must remain within CG limits to meet mission requirements.

- a. Removal of the HF- R/T Shock Mount. (See Figure 1.)

NOTE

All bonding straps will be retained with the helicopter for reinstallation.

- (1) Remove right Avionics door.
- (2) Remove four machine screws (1) and four flat washers (2) holding the HF R/T Hard Mount (3) in place.
- (3) Remove HF-R/T shock mount (4) and Hard Mount (3). Disconnect wiring bundles from side of HF-RT Hard Mount.
- (4) Reinstall four machine screws (1) and four flat washers (2) in mounting holes.

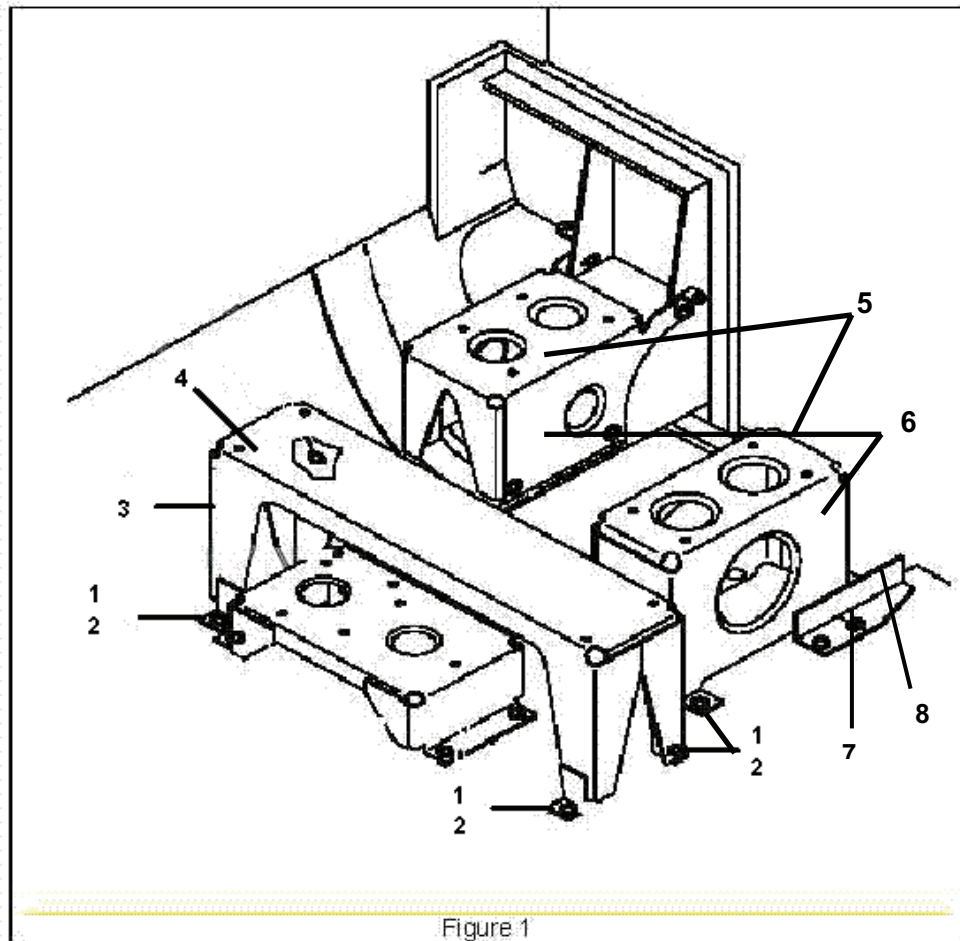

b. Removal KY-75 Shock Mount. (See Figure 1.)

- (1) Remove four machine screws (1) and four flat washers (2).
- (2) Remove rivets (7) and "L" shaped bracket (8).
- (3) Remove KY-75 Shock Mount (5) and Brackets (6).
- (4) Reinstall four screws (1) and four washers (2) in mounting holes.



WARNING

Isopropyl alcohol is flammable; do not use near open flames, near welding areas, or on hot surfaces. Do not use while smoking or while others are smoking. Inhalation of vapors can cause drowsiness, dizziness, and headache. Contact with skin may cause irritation. If liquid touches skin or eyes, flush thoroughly with water. Remove contaminated clothing. If vapors cause drowsiness, go to fresh air. When handling large quantities (greater than 1 gallon), work at air exhausted workbench or covered tank.

- (5) Clean area where rivets were removed with isopropyl alcohol.
- (6) Cover holes with masking tape.



WARNING

Filled epoxy resin may cause skin and eye irritation. Thoroughly wash skin area with soap and warm water and immediately flush eyes with water for 15 minutes. In all cases get immediate medical attention. When working with epoxy resin, wear approved protective gloves and goggles. Use in a well-ventilated area and avoid breathing vapors.

- (7) Insert Episeal 10-10 (Metal Set or equivalent) through tape using syringe.
- (8) Sand area after drying.
- c. Removal HF Antenna. (If Installed.) (See Figure 2.)
 - (1) At rear of fuselage loosen screw (1) on clamp (2).
 - (2) Remove 3 screws (3).
 - (3) Slide ring (4) and boot (5) toward rear of tailboom.
 - (4) Remove 18 screws (6) from access door (7).
 - (5) Slide access door (7) toward rear of tailboom.
 - (6) Remove four screws (8), washers (9) and nuts (10) from insulator (11).
 - (7) Slide insulator (11) toward rear of tailboom.
 - (8) Remove nut (12), washer (13), lockwasher (14) and washer (15).
 - (9) Remove jumper assembly (16) from antenna terminal (17). Retain hardware.

NOTE

One person is required to support center of HF antenna until antenna is removed.

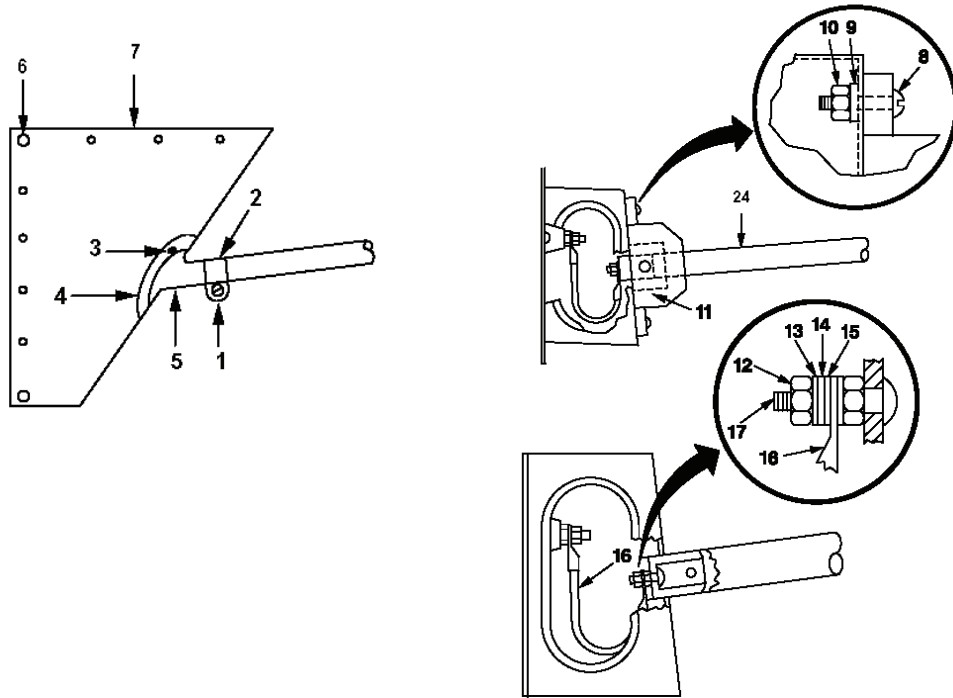

Figure 2

- (10) Remove screw (18), washer (19) and nut (20). (See Figure 3.)
- (11) Remove two screws (21), washers (22) and nut (23).
- (12) Remove HF antenna (24) from helicopter.
- (13) Remove screw (25), washer (26) and nut (27) from fitting (28) at fuselage end of antenna (24).
- (14) Remove rear support (29) and center support (30) and reinstall screws.
- (15) Remove insulator (11), access door (7), boot (5), ring (4), and clamp (2) from antenna (24).

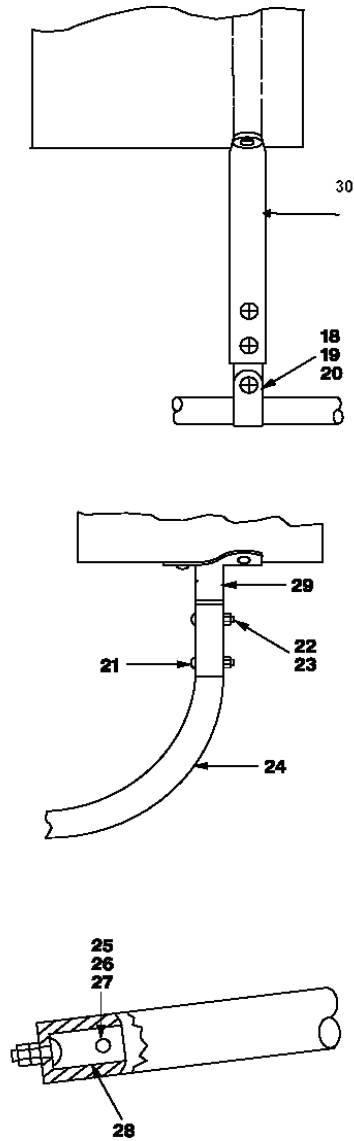

Figure 3

(16) Fabricate a cover plate from 2024 sheet stock using ring (4) from access panel (7) as a template.



WARNING

Epoxy primer coating is flammable. It contains lead and may cause irritation of nose, throat, eyes, skin, respiratory system and nervous system. Overexposure may result in headache, narcotic effect, nervousness, drying of skin, and possible death. Thoroughly wash skin area with soap and water and immediately flush eyes with water for 15 minutes. If ingested, do not induce vomiting. In all cases get immediate medical attention. When working with epoxy primer coating wear approved respirator, chemical splash goggles, solvent resistant gloves, apron, protective clothing, and barrier cream. Work in a well-ventilated area.

(17) Prime using MIL-PRF-23377 epoxy primer and paint the cover plate.

(18) Install the cover plate using the existing screws onto access panel (7).

d. Removal of HF-Antenna Coupler. (If installed.) (See Figure 4.)

(1) Gain access to HF antenna coupler (1) by removing four screws (2), washers (3), and exhaust port screen (4).

(2) Disconnect RF cable (5) from HF antenna coupler (1).

(3) Remove four screws (12), nuts (13), and washers (14) from bracket (15).

(4) Remove jamnut (16) and jumper assembly terminal (17) from stud (18).

(5) Support HF antenna coupler (1) and remove six mounting screws (19) and washers (20).

(6) Open aft electrical compartment door and remove HF antenna coupler (1).

e. Removal of the HF - Amplifier Coupler Mounting Rack. (See Figure 4.)

(1) Gain access to the aft electronics bay.

(2) Remove screws attaching the mounting rack (21) to the airframe structure.

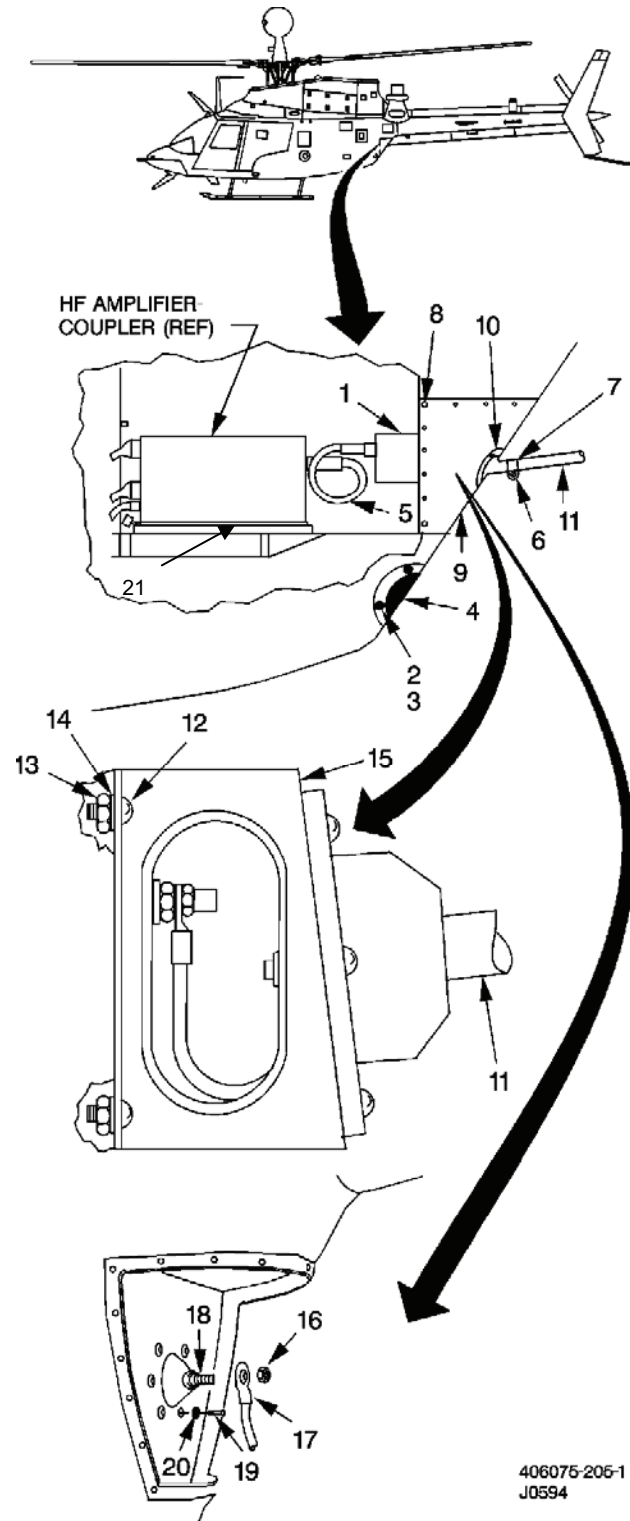

Figure 4

f. Removal of the PDU. (If installed.) (See Figure 5.)

(1) Disconnect electrical connector (1) from helicopter disconnect (2).

(2) Remove screw (3), washer (4), and clamp (5) securing PDU electrical cable (6) to cockpit overhead (7).

(3) Loosen height adjustment lock release levers (8) and adjust PDU (9) to gain access to cap screw (10) and down stop (11).

(4) Lock PDU (9) in position.

(5) Remove cap screw (10) and down stop (11) from front mount post (12).

(6) Loosen height adjustment lock release levers (8) and remove PDU (9) from mount assembly (13).

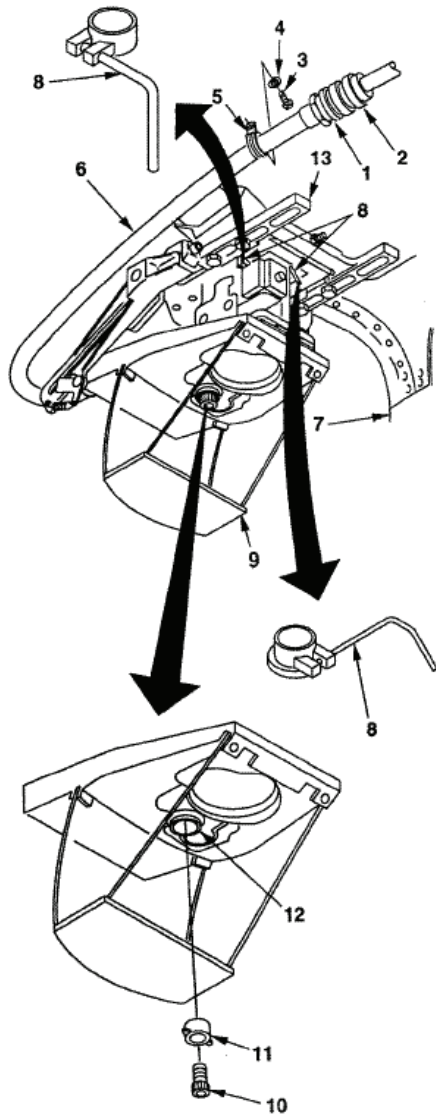

Figure 5

g. Removal of Pilot Display Unit (PDU) Mount Assembly. (See Figure 6.)

NOTE

Support PDU mount assembly during removal. Use allen wrench to ensure studs do not turn when removing nuts and washers.

(1) Remove four nuts (1) and washers (2) securing mount assembly (3), spacers (4), and shims (5) to forward studs (6) and aft studs (7) on PDU fitting (8).

(2) Remove mount assembly (3), spacers (4), and shims (5) from forward studs (6) and aft studs (7).

WARNING

Do not grind into mount when removing studs.

NOTE

Ensure windshield is protected from debris which could cause damage.

(3) Remove the studs (6 and 7) from the PDU Fitting by cutting with a grinder, leaving a small portion of the stud protruding. File remainder of stud level to surface of mount.

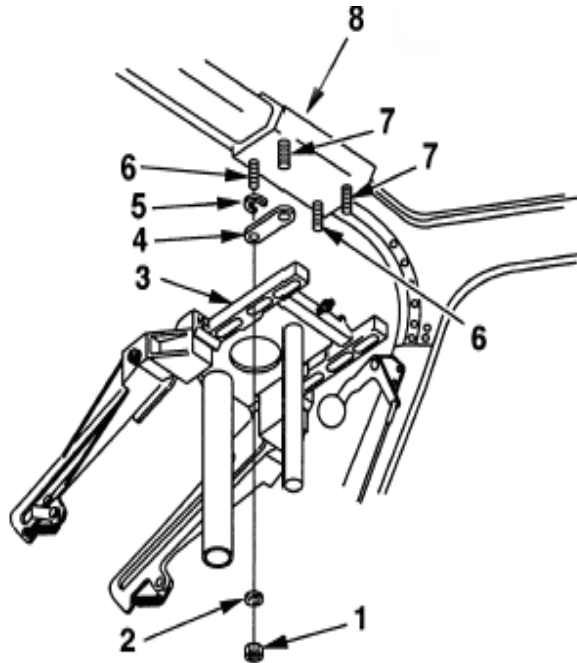

Figure 6



WARNING

Isopropyl alcohol is flammable; do not use near open flames, near welding areas, or on hot surfaces. Do not use while smoking or while others are smoking. Inhalation of vapors can cause drowsiness, dizziness, and headache. Contact with skin may cause irritation. If liquid touches skin or eyes, flush thoroughly with water. Remove contaminated clothing. If vapors cause drowsiness, go to fresh air. When handling large quantities (greater than 1 gallon), work at air exhausted workbench or covered tank.

- (4) Clean smoothed surface of stud using isopropyl alcohol.



WARNING

Epoxy primer coating is flammable. It contains lead and may cause irritation of nose, throat, eyes, skin, respiratory system and nervous system. Overexposure may result in headache, narcotic effect, nervousness, drying of skin, and possible death. Thoroughly wash skin area with soap and water and immediately flush eyes with water for 15 minutes. If ingested, do not induce vomiting. In all cases get immediate medical attention. When working with epoxy primer coating wear approved respirator, chemical splash goggles, solvent resistant gloves, apron, protective clothing, and barrier cream. Work in a well-ventilated area.

- (5) Prime area using MIL-PRF-23377 epoxy primer and paint.
- (6) Gain access to the right passenger side area.
- (7) Remove the Pilot PDU cable by removing 5 standoffs.

h. Removal of the PDU Cable. (See Figure 7.)

- (1) Gain access to the right side electronics bay and to the pilot area.
- (2) Remove the machine screws and standoffs securing the PDU cable.
- (3) Remove the PDU Cable.
- (4) Remove PDU Cable Bracket (1) held in by 4 rivets.
- (5) Cut off clamp studs on back door frame.

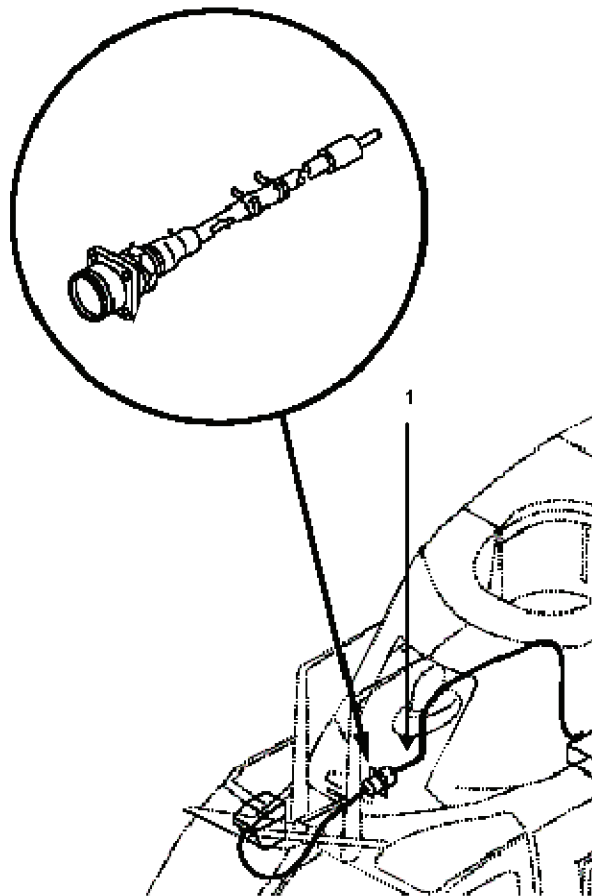

Figure 7

- i. Remove Cargo Handle, Cables. (See Figure 8.)

NOTE

If aircraft is equipped with Raschel seat cover and armor panel, remove and install in accordance with TM 1-1520-248-23, Task 2-2-24 and Task 2-2-40.

- (1) Cut cable and electrical wire for emergency release where they enter the lower fuselage.
- (2) Remove rear center console panel under collective.
- (3) Locate and remove cargo release wiring. (See Figure 10, Item 32.)
- (4) Remove bracket assembly (6) and reinstall screws.

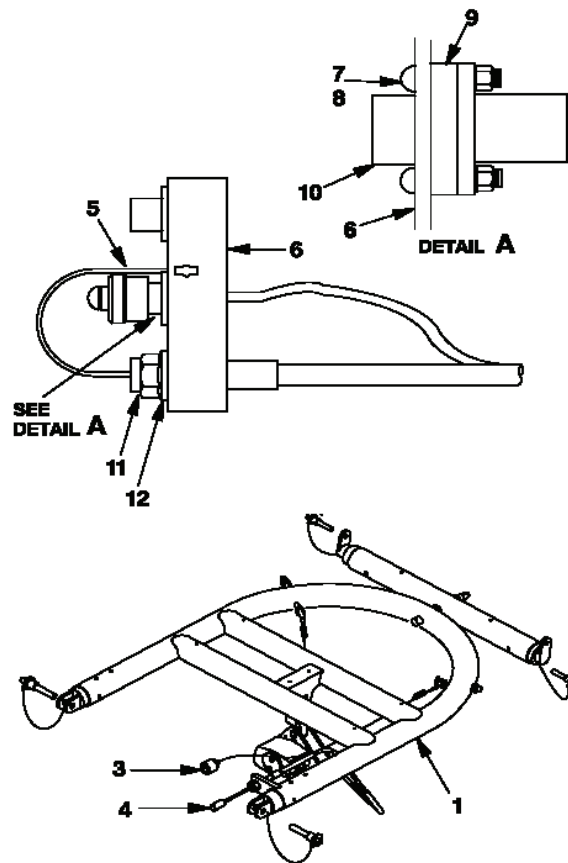

Figure 8

- (5) Remove screw (13), washer (14), and spacer (15). (See Figure 9.)
- (6) Remove clamp (16) from cable assembly (5).
- (7) Remove nut (17), washer (18), and screw (19).
- (8) Remove clamp (20) from cable assembly (5).
- (9) Remove clamp (21) from forward crosstube.
- (10) Remove screw (22), washer (23), and spacer (24).
- (11) Remove clamp (25) from cable assembly (5).
- (12) Remove grommet (26) from bottom of fuselage.

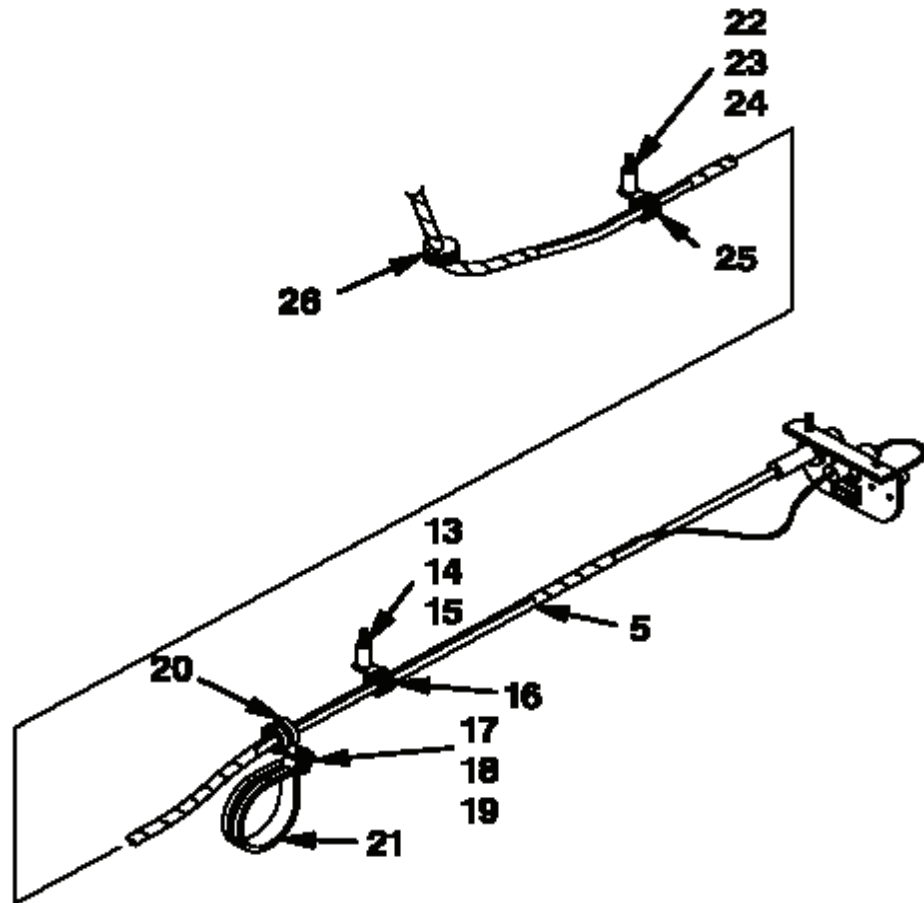

Figure 9

(13) Remove three screws (29) and three washers (30) securing mount (31) to console (32). Remove mount and cable. (See Figure 10.)

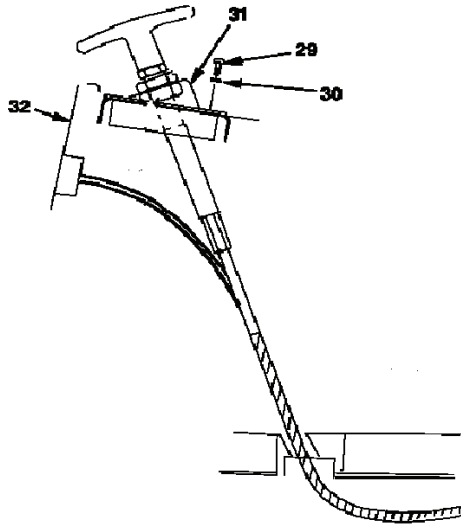

Figure 10

(14) Fabricate a cover plate from 2024 sheet stock to cover area on center console.



WARNING

Epoxy primer coating is flammable. It contains lead and may cause irritation of nose, throat, eyes, skin, respiratory system and nervous system. Overexposure may result in headache, narcotic effect, nervousness, drying of skin, and possible death. Thoroughly wash skin area with soap and water and immediately flush eyes with water for 15 minutes. If ingested, do not induce vomiting. In all cases get immediate medical attention. When working with epoxy primer coating wear approved respirator, chemical splash goggles, solvent resistant gloves, apron, protective clothing, and barrier cream. Work in a well-ventilated area.

(15) Prime with MIL-PRF-23377 epoxy primer and paint the fabricated cover plate.

(16) Attach cover plate to center console using screws removed earlier.



WARNING

Isopropyl alcohol is flammable; do not use near open flames, near welding areas, or on hot surfaces. Do not use while smoking or while others are smoking. Inhalation of vapors can cause drowsiness, dizziness, and headache. Contact with skin may cause irritation. If liquid touches skin or eyes, flush thoroughly with water. Remove contaminated clothing. If vapors cause drowsiness, go to fresh air. When handling large quantities (greater than 1 gallon), work at air exhausted workbench or covered tank.

(17) From underneath aircraft, clean area where cable assembly entered the aircraft using isopropyl alcohol.

(18) Cover hole with masking tape.



WARNING

Filled epoxy resin may cause skin and eye irritation. Thoroughly wash skin area with soap and warm water and immediately flush eyes water for 15 minutes. In all cases get immediate medical attention. When working with epoxy resin, wear approved protective gloves and goggles. Use in well-ventilated area and avoid breathing vapors.

(19) Insert Episeal 10-10 (Metal Set or equivalent) through tape using syringe.

(20) Sand area after drying.



WARNING

Epoxy primer coating is flammable. It contains lead and may cause irritation of nose, throat, eyes, skin, respiratory system and nervous system. Overexposure may result in headache, narcotic effect, nervousness, drying of skin, and possible death. Thoroughly wash skin area with soap and water and immediately flush eyes with water for 15 minutes. If ingested, do not induce vomiting. In all cases get immediate medical attention. When working with epoxy primer coating wear approved respirator, chemical splash goggles, solvent resistant gloves, apron, protective clothing, and barrier cream. Work in a well-ventilated area.

(21) Prime using MIL-PRF 23377 epoxy primer and paint the area.

(22) Reinstall rear center console panel under collective.

j. Remove Cargo Release Switch. (See Figure 11.)

(1) Cut wires connected to cargo release switch.

(2) Remove nut (1), washer (2), and switch guard (3) from cargo release switch (4).

(3) Remove cargo release switch (4) from switch support (5).

(4) Cut shrink-wrap approximately 1/2 inch to expose cargo wires where they enter the collective.

(5) Cut and cap wires and recover with existing shrink-wrap.

(6) Fabricate a cover plate from 2024 sheet stock to cover area on switch support (5).

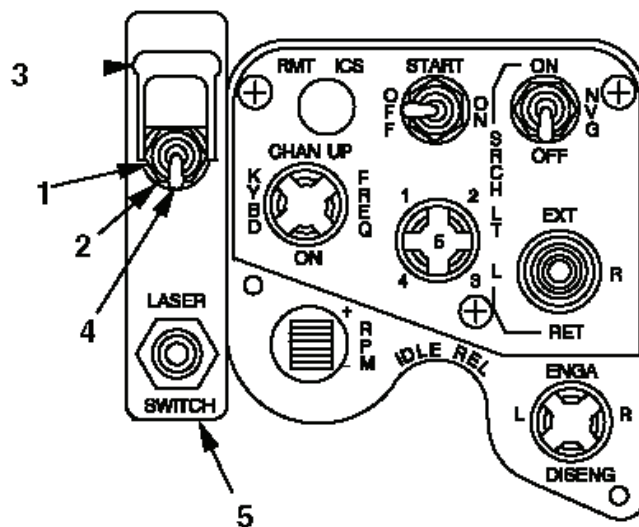

Figure 11

**WARNING**

Epoxy primer coating is flammable. It contains lead and may cause irritation of nose, throat, eyes, skin, respiratory system and nervous system. Overexposure may result in headache, narcotic effect, nervousness, drying of skin, and possible death. Thoroughly wash skin area with soap and water and immediately flush eyes with water for 15 minutes. If ingested, do not induce vomiting. In all cases get immediate medical attention. When working with epoxy primer coating wear approved respirator, chemical splash goggles, solvent resistant gloves, apron, protective clothing, and barrier cream. Work in a well-ventilated area.

(7) Prime using MIL-PRF-23377 epoxy primer and paint the cover plate.

(8) Attach cover plate to switch support (5) using rivets (NSN 5320-00-269-9400).

k. Cargo Hook Switch on Forward Overhead Console.

(1) Open forward overhead circuit breaker panel.

(2) Remove wires from cargo release switch and cap wires.

(3) Using black paint or equivalent, cover cargo hook switch label on outside of circuit breaker panel.

I. Remove FM Comparator. (See Figure 12.) (CDS2 aircraft)

- (1) Gain access to comparator (1) on inside roof of helicopter.
- (2) Disconnect two electrical connectors (2) and four coax connectors (3) from comparator (1).
- (3) While supporting comparator (1), remove one screw (4) and washer (5).
- (4) Loosen three captive screws (not shown) (6) and remove comparator (1) from helicopter.
- (5) If ARC201 radio is installed, remove stand-off coupler 2304A3.

(6) Replace connector (2304Z2P5) on cable (2ARC186-103A(7)) with new connector (part number M39012/17-0502, NSN 5935-01-046-2037).

(7) Remaining coax cables will be removed from helicopter during removal of FM Antenna Coupler in step m.

- (8) Retain and secure electrical connectors.

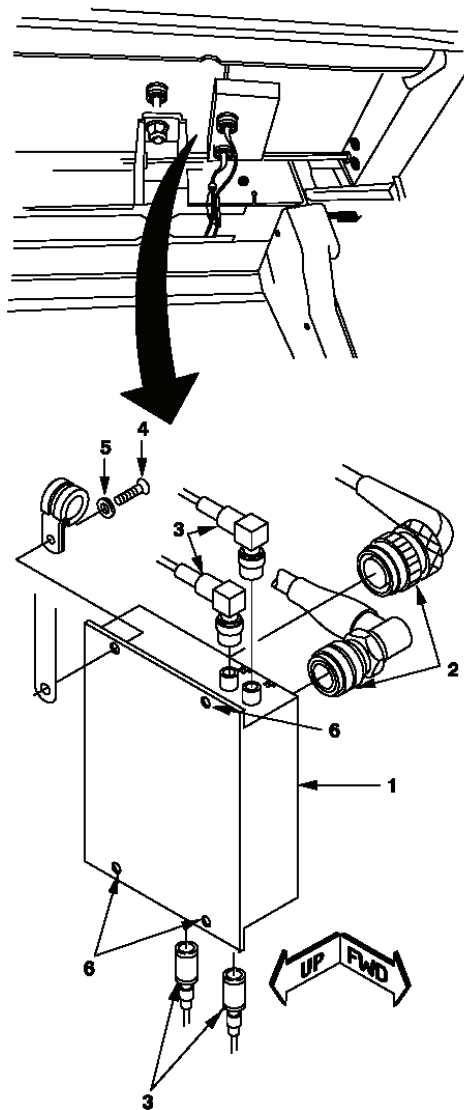

Figure 12

m. Remove FM Antenna Coupler (See Figure 13.) (CDS2 aircraft)

(1) Disconnect five coax connectors (2) from antenna coupler (1).

(2) Disconnect electrical connector (3) from antenna coupler (1).

(3) Retain and secure electrical connector.

(4) Support antenna coupler (1) and remove four screws (4), lockwasher (5), and washers (6). Retain for later use.

(5) Remove antenna coupler (1) from helicopter.

(6) Remove the three coax cables (2ARC186-34A, -35A, and -36A) between coupler and comparator.

(7) Disconnect cable from L/H homing antenna, and remove cable 2 ARC 186-39A from coupler to antenna.

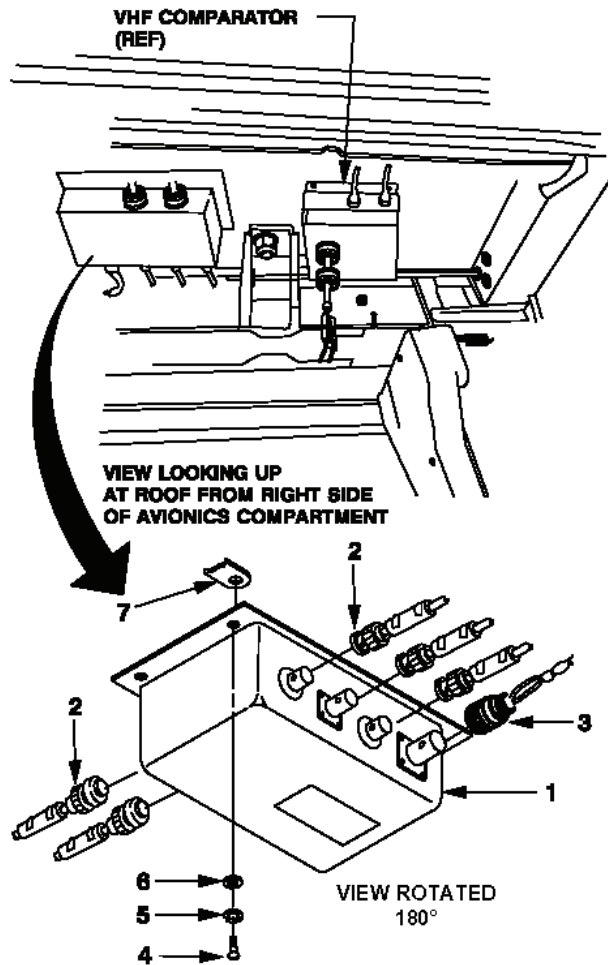

Figure 13

- (8) Fabricate angle bracket from 0.032 inch 7075T6 aluminum IAW figure 14. Treat IAW TM 1-1500-204-23 and paint to match interior of cabin.

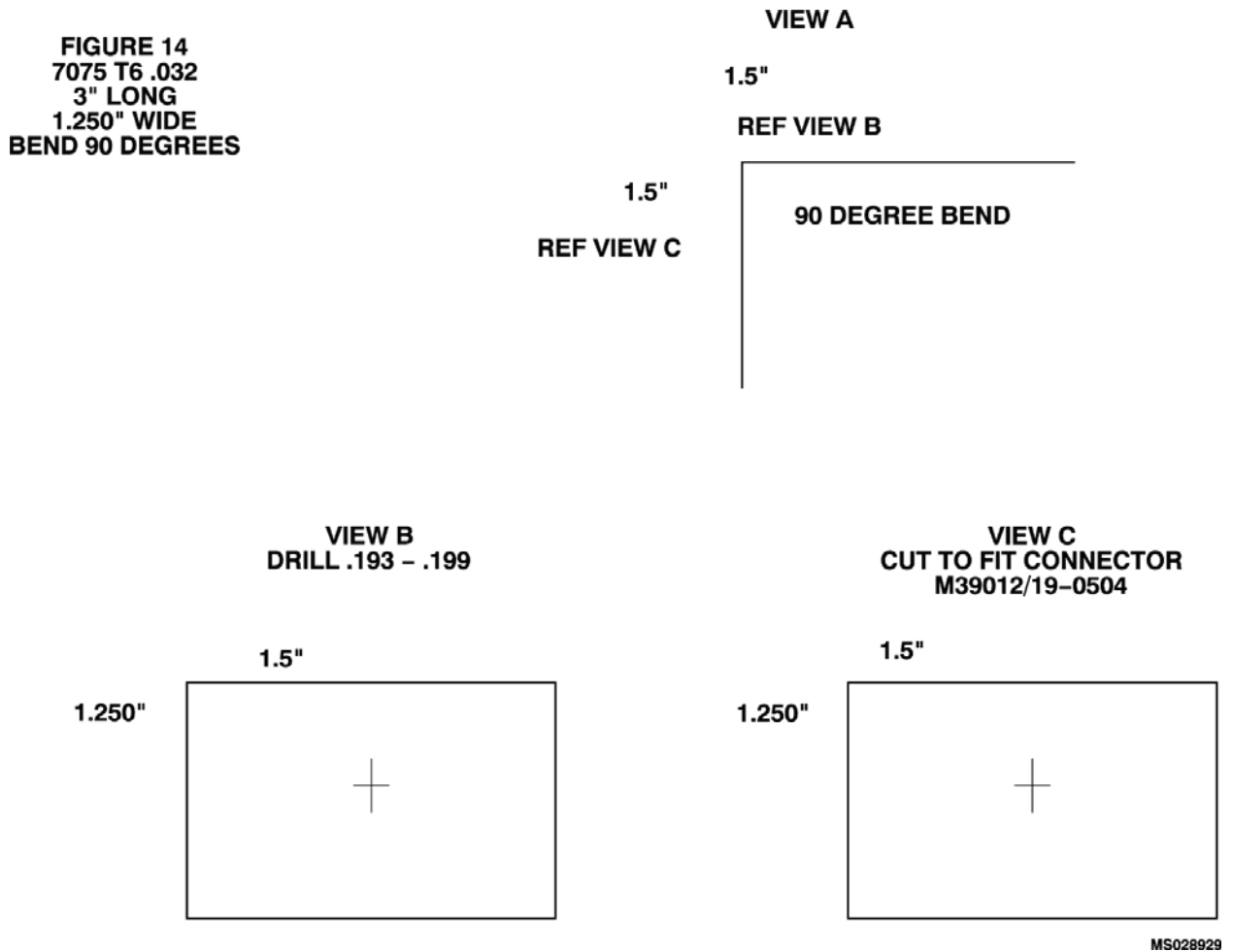

Figure 14.

(9) Using one of each retained screw (4), lockwasher (5) and washer (6), install fabricated angle bracket in cabin roof at forward right insert previously used by coupler.

(10) Install new connector (part number M39012/17-0502).

(11) Attach 2304Z2P2 to new connector on angle bracket.

n. Remove FM Antenna. (See Figure 15)

(1) Disconnect coax connector (1) for left side.

(2) Remove old sealing compound from mounting screws (2), mount (3), and surrounding mounting surfaces using plastic scraper.

(3) Remove four mounting screws (2) from mount (3).

(4) Remove homing antenna (4).

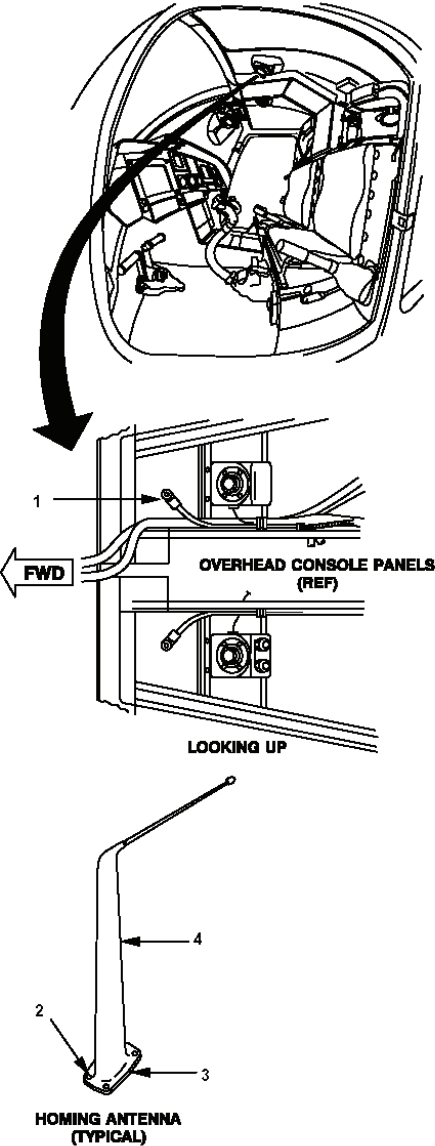

Figure 15 |

(5) Fabricate a cover plate from 2024 sheet stock to cover area on roof.



WARNING

Epoxy primer coating is flammable. It contains lead and may cause irritation of nose, throat, eyes, skin, respiratory system and nervous system. Overexposure may result in headache, narcotic effect, nervousness, drying of skin, and possible death. Thoroughly wash skin area with soap and water and immediately flush eyes with water for 15 minutes. If ingested, do not induce vomiting. In all cases get immediate medical attention. When working with epoxy primer coating wear approved respirator, chemical splash goggles, solvent resistant gloves, apron, protective clothing, and barrier cream. Work in a well-ventilated area.

(6) Prime using MIL-PRF-23377 epoxy primer and paint the cover plate.



WARNING

Sealing compound is flammable. Do not use near heat, open flames, or sparks. Overexposure can cause irritation of skin and eyes, headache, nausea, vomiting, and systemic problems. Thoroughly wash skin area with soap and water and immediately flush eyes with water for 15 minutes. In all cases get immediate medical attention. Wear approved protective gloves and goggles. Avoid breathing of vapors and prolonged or repeated skin contact.

(7) Apply a layer of sealant, MIL-S-8802, as necessary, to cover plate.

(8) Attach cover plate using screws removed earlier.

o. Removal of Armor Plates.

(1) Remove armor plate and existing hardware from engine cowling doors.

12. SUPPLY/PARTS AND DISPOSITION.

a. Parts required.

NOMENCLATURE	NSN	CAGE	PART NUMBER
Connector, Plug, Electrical	5935-01-046-2037	91836	M39012/17-0502
Rivet, Blind	5320-00-269-9400		

b. Requisitioning instructions. Not applicable.

c. Bulk and consumables. As required.

d. Disposition of hazardous material. Not applicable.

- e. Disposition.
 1. HF-Antenna Coupler: Return to Supply.
 2. Pilots Display Units: Return to Supply.
 3. Pilots Display Unit Power Cable: Return to Supply.
 4. FM Comparator and Cables: Return to Unit.
 5. FM Antenna Coupler and Cables: Return to Unit.
 6. FM Antenna and Cables: Return to Unit.
 7. Engine Armor Plates: Return to Unit.

13. SPECIAL TOOLS, JIGS, AND FIXTURES REQUIRED. As required.

14. APPLICATION.

- a. Category of maintenance. AVIM. Aircraft downtime will be charged to AVIM.
- b. Time required for this action.
 - (1) Total of 8 manhours using 4 people.
 - (2) Total of 7 manhours downtime for aircraft.
- c. Publications which will require change as a result of this action. Not applicable.

15. REFERENCES.

- a. TM 1-1520-248-23, Aviation Unit and Intermediate Maintenance Manual for Army OH-58D Helicopter.
- b. TM 1-1520-248-23P, Aviation Unit and Intermediate Maintenance Repair Parts and Special Tools List for Helicopter, Observation OH-58D.
- c. TM 1-1500-204-23, General Maintenance Aircraft Manual.
- d. TM 9-1090-214-23&P, Aviation Unit And Aviation Intermediate Maintenance Manual For Armament Subsystem Helicopter .50 Caliber (12.7mm) Machine Gun: 2.75 Inch Rocket System And Missile Integration.
- e. TM 11-1520-248-23, Aviation Unit and Intermediate Maintenance Manual for Army Model OH-58D Helicopter.

16. RECORDING AND REPORTING REQUIREMENTS.

- a. Reporting Compliance Suspense Date (Aircraft). Not applicable.
- b. Task/Inspection Reporting Suspense Date (Aircraft). Not applicable.
- c. Reporting Compliance Suspense Date (Spares). Not applicable.
- d. Task/Inspection Reporting Suspense Date (Spares), Not applicable.
- e. The following forms are applicable and are to be completed in accordance with DA PAM 738-751.
 - (1) DA Form 2408-13, Aircraft Status Information Record.
 - (2) DA Form 2408-13-1, Aircraft Inspection and Maintenance Record.
 - (3) DA Form 2408-13-2, Related Maintenance Actions Record.
 - (4) DA Form 2408-15, Historical Records for Aircraft.
 - (5) DA Form 365, Weight and Balance Record.

17. WEIGHT AND BALANCE. Weighing of the aircraft will be accomplished after removal and forms updated as required.

18. POINTS OF CONTACT.

a. Maintenance Point of Contact is Mickey Horan, AMSAM-MMC-AV-SO, DSN 897-1389 or (256) 313-1389. Fax is DSN 788-6758 or (256) 842-6758. E-mail is "michael.horan@redstone.army.mil".

b. Technical Point of Contact is Kevin Cahill, AMSAM-RD-AE-I-D-O, DSN 897-2350, ext 9821 or (256) 705-9821. Fax is DSN 897-2350, ext 9928 or (256) 705-9928. E-mail is "kevin.cahill@rddec.redstone.army.mil".

c. Logistical Point of Contact is Randy Lyle, AMSAM-AV-AS-ASH, DSN 645-7971 or (256) 955-7971. E-mail is "randy.lyle@redstone.army.mil".

d. Forms and Records Point of Contact is Ann Waldeck, AMSAM-MMC-MA-NM, DSN 746-5564 or (256) 876-5564. Fax is DSN 746-4904 or (256) 876-4904. E-mail is "ann.waldeck@redstone.army.mil".

19. Reporting of Errors and Recommending Improvements. You can help improve this bulletin. If you find mistakes or know of any way to improve procedures, please let us know. Mail your letter, DA Form 2028 (Recommended Changes to Publications and Blank Forms), directly to: Commander, U.S. Army Aviation and Missile Command, ATTN: AMSAM-MMC-MA-NP, Redstone Arsenal, AI 35898-5000. A reply will be furnished to you. You may also provide DA Form 2028 information to AMCOM via e-mail, fax, or the World Wide Web. Our fax number is: DSN 788-6546 or Commercial 256-842-6546. Our e-mail address is: 2028@redstone.army.mil. Instructions for sending an electronic 2028 may be found at the back of this bulletin. For the World Wide Web use: <https://amcom2028.redstone.army.mil>

By Order of the Secretary of the Army:

Official:

ERIC K. SHINSEKI
General, United States Army
Chief of Staff

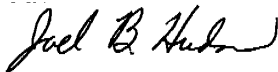

JOEL B. HUDSON
Administrative Assistant to the
Secretary of the Army

0325902

DISTRIBUTION:

To be distributed in accordance with Initial Distribution Number (IDN) 314100 requirements for TB 1-1520-248-30-01.